

TANNOY®

IN | WALL

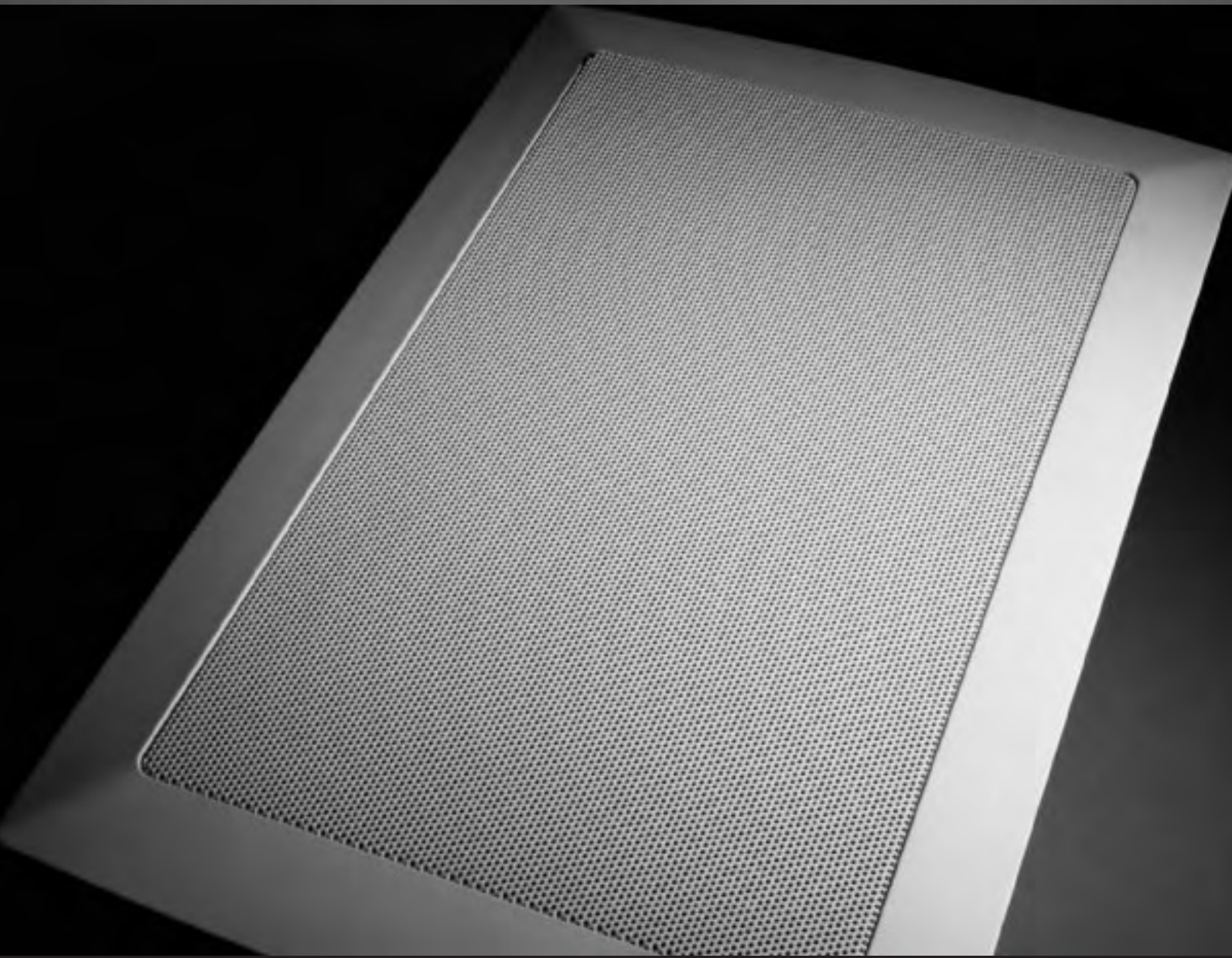

 **DUAL™**
CONCENTRIC

 **WIDEBAND™**
TECHNOLOGY

i w 4 D C
OWNER'S MANUAL



OWNER'S MANUAL

CONTENTS

INTRODUCTION	2	CONNECTING THE iw4 DC	7
FEATURE IDENTIFICATION	3	SPEAKER LOADING VOLUME	8
ACCESSORIES		TECHNICAL SPECIFICATIONS	9
TECHNOLOGY	4	TECHNICAL DRAWINGS	10
IMPORTANT NOTES		NOTES	11
INSTALLATION	5		

INTRODUCTION

Tannoy in-wall speaker systems offer a fresh perspective for the custom installation product arena. For the first time, highly regarded cabinet-based monitor quality speaker systems are available as in-wall designs. These models have been designed therefore to provide a performance level more in keeping with that of conventional loudspeakers. As a result Tannoy In-wall products find applications in Multi-Room audio installations, Home Theatre systems and in the many other applications where space is at a premium but ultimate sound quality is still paramount.

Drive units and crossover assemblies, as used in many of the existing Tannoy loudspeaker ranges, have been utilised to ensure that sound quality is not compromised, and a robust cable termination block is fitted to provide the speaker with optimum input signal integrity.

Complementing any style of décor, the perforated metal grille and discreet moulded ABS baffle panel frame can be painted to blend in seamlessly with the domestic environment. The result is a system offering audiophile quality sound with minimal invasion of the living space.

Thank you for selecting Tannoy loudspeakers; developed in the UK by our dedicated team of design engineers, they are the choice of discriminating music and movie lovers the world over. Excellence is designed into our loudspeakers from the start. Careful selection of the very best components combined with strict quality control procedures during the production process ensures this level of excellence is maintained. We feel confident that you will enjoy your new Tannoy loudspeakers for many years to come.

Please take time to read the rest of this owner's guide before using your loudspeakers to gain maximum effect from their use. Once you have installed your new loudspeakers please complete and return the registration document – this does not limit your legal rights.

Loudspeakers are electromechanical devices that 'run-in' through use; performance will therefore improve after an initial period of 24hrs continuous use. Once they have been further run-in over a considerably longer period, there will be clear enhancement of the stereo imaging, mid-band quality and bass performance characteristics.

WARRANTY

All of our products have been produced and tested with care and precision to give first-class service.

All passive components are guaranteed for a period of five years from the date of purchase from an authorised Tannoy dealer (subject to the absence or evidence of misuse, overload, or accidental damage).

All active and electronic components are guaranteed for a period of one year from the date of purchase from an authorised Tannoy dealer (subject to the absence or evidence of misuse, overload, or accidental damage).

All active and electronic components are guaranteed for a period of one year from the date of purchase from an authorised Tannoy dealer (subject to the absence or evidence of misuse, overload, or accidental damage).

If at anytime during this warranty period the equipment proves to be defective for any reason other than accident, misuse, neglect, unauthorised modification or fair wear and tear, we will repair any such manufacturing defect or, at our option replace it without charge for labour, parts or return carriage.

If you suspect a problem with a tannoy product then, in the first instance, discuss it with your Tannoy dealer. If you require further assistance then we ask that you deal directly with your local Tannoy distributor.



EXPLODED VIEW OF iw4DC

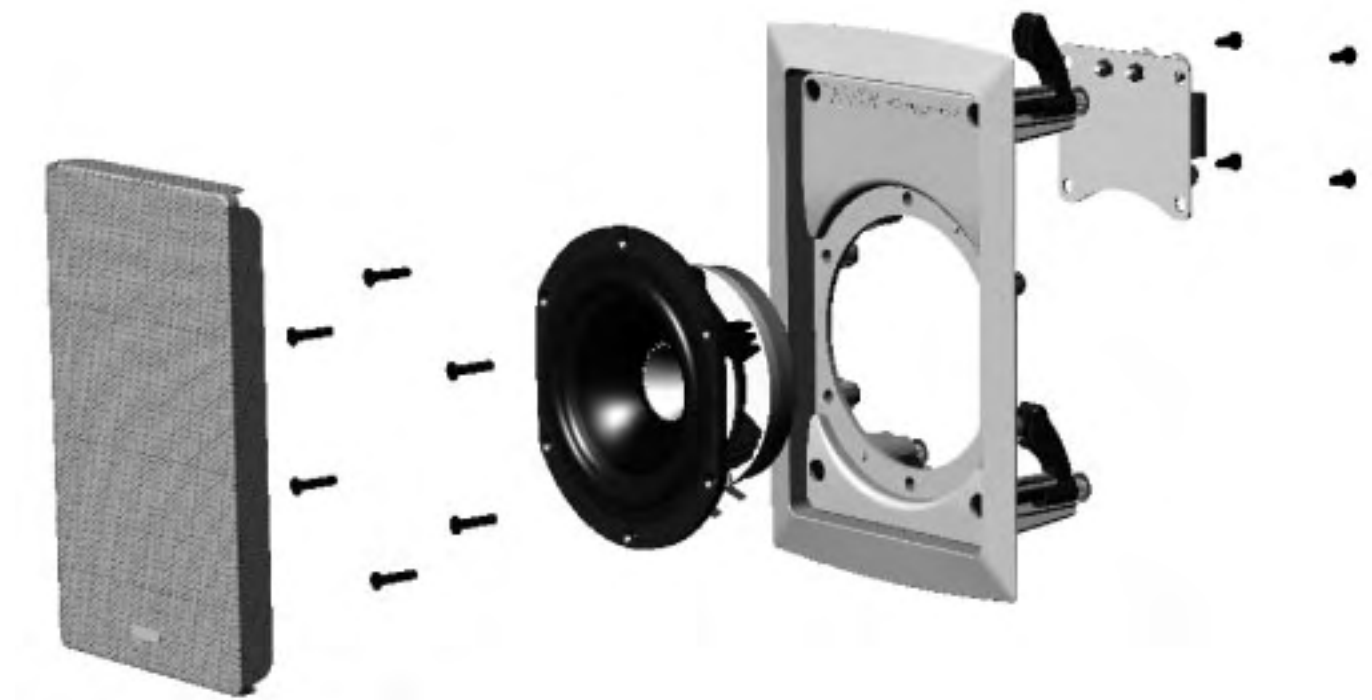

STANDARD ACCESSORIES

The following accessories are provided with the iw4DC



CUT-OUT TEMPLATE

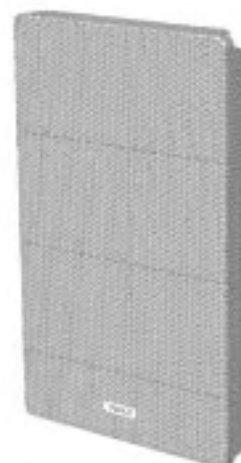

GRILLE

WIDEBAND™ TECHNOLOGY

Tannoy has incorporated its own WideBand™ technology into the design of the iw4 DC. Not only does this exceptional in-house technology resolve the fine detail of high frequency information but it also effectively enhances the listening experience throughout the whole frequency range. The WideBand™ high frequency system creates an increased immediacy, airiness and impact, making music sound more natural and true to life.

Music contains transient information and rich harmonics beyond the range of human hearing for pure tones. Even bass notes have leading edge transients reaching 30kHz. The Tannoy WideBand™ high frequency unit, which is integrated into the Dual Concentric™ driver, will accurately reproduce the leading edge of individual sounds allowing the listener to experience the entire bandwidth, by extending the frequency response to 54 kHz.

In addition, the extension of the frequency response, by fully two octaves, corrects time and phase response within the bandwidth of normal human hearing. Taking these acoustical phase anomalies beyond the audible range adds realism to the soundstage through improvements in imaging and the placement of instruments.

DUAL CONCENTRIC™ TECHNOLOGY

The iw4DC utilises the latest 4" Dual Concentric™ driver. Intensive research and development has produced an all-new version of this proven technology that builds upon the legendary performance of this exclusive Tannoy driver design.

The time coherent, point source and constant directivity nature of the dispersion characteristics inherent in the Dual makes it an accepted industry standard in studio monitoring. By exceeding the rigorous demands of the recording and mastering environment Tannoy can ensure that playback performance in the home, whether installed in two channel stereo, multi channel home cinema or in distributed audio multi-room applications, is strictly controlled to accurately reflect the sound engineers artistry.

In nature all sounds emanate from a single point in space. The high frequency unit of the Dual, centrally mounted in the throat of the main mid/bass driver, is so positioned as to acoustically replicate this single point source; delivering an open and natural sound with a very wide imaging 'sweet spot', which creates an expansive soundstage with remarkably focussed placement of vocals and instrumentation.



PAINTING

Before proceeding with the installation the grille and baffle panel can be painted to blend with the surrounding décor.

- When painting the baffle be sure to carefully mask off the driver assemblies. It is important to ensure that paint does not come into contact with the cone, roll surround or HF unit. Several thin coats of paint will provide a superior finish to that achieved by one applied too thickly.

AMPLIFIER MATCHING

Consult the enclosed product specification sheet for the acceptable power range of amplifier matching. The high peak power handling of Tannoy loudspeakers permits responsible use with more powerful amplifiers - please read the Warranty.

As with all loudspeaker systems, the power handling is a function of voice coil thermal capacity. Care should be taken to avoid overdriving any amplifier, as this will cause output overload resulting in 'clipping' or distortion within the output signal. If amplifier output overload conditions exist for an extended period then the loudspeakers can be damaged.

Generally a higher power amplifier running hard, but free of distortion, is less likely to damage the loudspeaker than a lower power amplifier continually clipping. Remember also that a high powered amplifier running at less than 90% of output power generally sounds a great deal better than a lower powered option struggling to achieve 100%. An amplifier with insufficient drive capability will not allow the full performance of the loudspeakers to be realised (refer to the specification table in this manual for recommendations).

CABLE CHOICE

Always use the best quality of cable available within your budget. High quality audio signals passing from the amplifier to the loudspeaker are unusual in their demands on the cable. Wide dynamic range and frequency bandwidth information has to coexist with the ability to transmit peak currents of at least 10amps, without incurring any loss or signal impairment. This explains why the sound quality of the information reproduced by the loudspeakers is so dependant on the physical properties of the cables connecting them to the amplifier.

Technically, we recommend two-core cable with cross section area not less than 1.5mm² (14 gauge) for cable runs of up to 3 metres. For longer lengths we would suggest that you use cable with a minimum cross sectional area of 2.5mm² (12 gauge). We do not recommend the use of braided (Litz) or small diameter coaxial cables as these have a high capacitance that may affect the stability of certain amplifiers.

INSTALLATION

WARNING

If adding new speakers to an existing installation, or simply replacing old ones, you must ensure that the amplifier driving the system is switched OFF.

WARNING

Prior to proceeding with the installation ensure that you determine the position of electrical cabling, pipe work and wall studs. Having selected a wall location clear of any obstruction measure carefully to ensure the correct placement.

1. OVERVIEW

Tannoy In-wall loudspeakers have been designed for installation into standard stud partition wall systems constructed with 102mm by 51mm (4" by 2") timber at 406mm (16") centres. However, it is envisaged that they will generally be used in cavity wall installations constructed with standard thickness plasterboard. These are guidelines and therefore do not preclude use of the Tannoy In-wall products in different locations and a wide range of other wall construction types as long as they have a secure clamping surface up to maximum thickness of 25.4mm (1").

Driver cone movement at low frequencies may become excessive unless steps are taken in the wall cavity void behind the loudspeaker to provide a well sealed and accurately controlled rear 'enclosure' volume, this will effectively act as an 'enclosure' behind the speaker (see Speaker Loading Volume section in this manual). Failure to ensure this will affect the bass and midrange performance unfavourably.

2. POSITIONING

There is a great deal of mounting location flexibility with both models when used in home cinema or multi channel systems. In particular, please note that due to the unique point source symmetrical dispersion properties of the Tannoy Dual Concentric™ drive unit, iw4DC can be mounted in either portrait (in stud partition wall situations) or landscape positions where sufficient space exists behind the wall surface.

To achieve the optimum spectral and stereo performance select your mounting location as follows:

- Vertical plane

Align the front baffle centres at intended listening height, usually dictated by the normal seated listening position. For audio use, when positioned in front of the listener, this will usually be in the range of 1100mm to 1700mm (43" to 67"). As home cinema rear effects speakers mounted on the rear walls of the room, the mounting height range is 1530mm to 2140mm (60" to 84").

- Horizontal plane

The loudspeakers should be located between 1500mm to 4500mm (60" to 180") apart – the room size and shape will dictate the final mounting location, but generally the listening position, when used as a stereo pair, should be set slightly further away than the speakers are apart.

Where the In-walls are used as rear effects speakers in a home cinema system the ideal viewing point will establish the distance from the rear wall to the listening position. Avoid positioning the loudspeakers in corners of the room, as this will have a negative effect on performance; maintain a distance of 1000mm (39") from a corner.

SPEAKER FITTING

REMEMBER.... MEASURE TWICE – CUT ONCE!

- Once the mounting location has been selected use the template provided to mark out the area of wall material to be cut out. Carefully remove the waste, checking again that there are no interferences from studs/wire/pipes etc.
- Install the loudspeaker cabling ensuring that the wiring route is laid clear of all screws and nails that could potentially damage the cable insulation. Allow sufficient cable length at the speaker end to allow for unrestricted connection.
- It is necessary to block off the void behind the speaker by suitable means (insulation material or foam) to create an "enclosure" area. This will offer the speaker the required loading volume as detailed in the specification section of this manual.
- It is important to provide some acoustic damping between the speaker and the rear wall surface. We recommend use of a BAF sheet (Bonded Acrylic Fibre). Ensure that materials used comply with local fire and building regulations.

- Strip 8mm (1/4 inch) of shielding from the end of the speaker cables in preparation for connection to the spring terminals on the rear of speaker. Check that the clamping arms are aligned as shown prior to insertion in the wall.
- Connect the speaker cable observing the correct wiring polarity. The positive terminal (marked + and coloured red) should receive the positive cable (usually marked with a repeated stamped name, line or raised rib) and the negative terminal (marked – and coloured black) the negative cable.
- Insert the baffle into pre-prepared hole in the wall, ensuring that the speaker wire is located securely away from the driver – contact with the driver cone will cause annoying buzzes.
- Each of the six clamp screws can now be tightened (clockwise). Starting at one corner then moving to the opposite corner, tightening sufficiently to check for visual orientation, before proceeding to tighten the other two corners. Finish off by tightening the two middle clamps.



Clamps in preinstall position

WARNING

- Do not over tighten the screws – this is unnecessary to achieve a strong acoustic seal to the wall and risks damaging the wall surface
- Repeat the installation procedure for the other loudspeakers and complete the connection process to the amplifier. Once again ensure that correct cable polarity is observed.
- Switch on the amplifier with the volume control at its lowest setting. Select a signal source and slowly turn up the volume to a low level. Check that bass and treble information comes from both speakers – if not, switch off the amplifier and recheck the connections.
- Carefully check the area surrounding the installation and ensure that there are no buzzes or rattles that could potentially impair enjoyment of the system – If there are then locate and silence the causes using cable ties or suitable packing material.
- Optimum performance will be assisted by the use of silicone sealant, or similar material, to seal gaps, for instance, between the studs and the wallboard material. This cavity sealing will help to create a near airtight seal.



GRILLE FITTING AND REMOVAL

- The grille should be carefully fitted to the front baffle aperture, by lining up the edges of the grille carefully with the baffle. To avoid indentation damage do not press the centre of the grille; apply even pressure to the corner as it is pressed firmly into position.
- To remove the grille loop an opened paper clip, or similar length of firm wire, through two holes near a corner and pull gently. The grille is intended to be a tight fit, so insert the wire at each corner in turn pulling carefully to avoid distortion of the mesh.



Fig 8

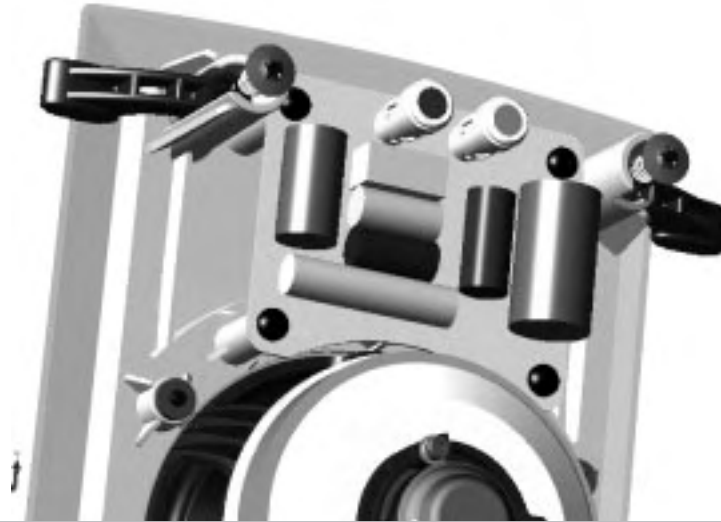

The robust spring loaded terminals are designed to take substantial high quality loudspeaker cable. Strip off approximately 8mm (1/4") of the outer protective layer and twist the inner cores together. Depress the spring-loaded terminal and insert the core ensuring that correct polarity is maintained - positive to positive and negative to negative (or red to red and black to black). The cable will have the negative (-) core marked by a solid dashed black line.

WALL CLAMP MECHANISM

PLEASE CONSULT THE INSTALLATION SECTION OF THIS MANUAL BEFORE PROCEEDING.

A unique six way clamp mechanism has been designed to provide the acoustically optimum bond to the wall surface without risk of distortion to the loudspeaker baffle.

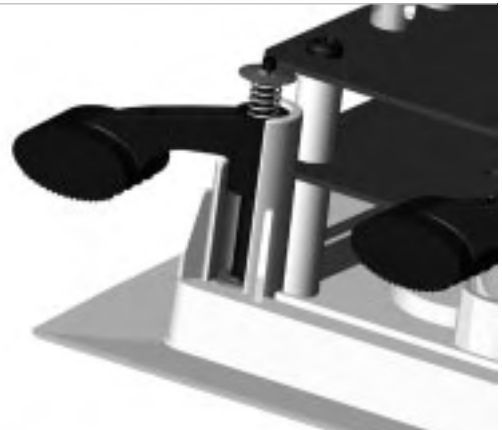

The iw4DC has four mounting clamps and screws. As these four screws are tightened, the immensely strong polycarbonate clamping arms will automatically swing round into the locking position and locate securely to the inside of the wall surface.

The design also allows for simple removal or reorientation of the loudspeaker. The spring-loaded clamp mechanism ensures that as the screws loosened (turned anticlockwise) the clamp arm travels along its guide before turning itself into the rest position. The captive locking system ensures that the clamp arm cannot drop off the end of the screw to be lost in the wall cavity.

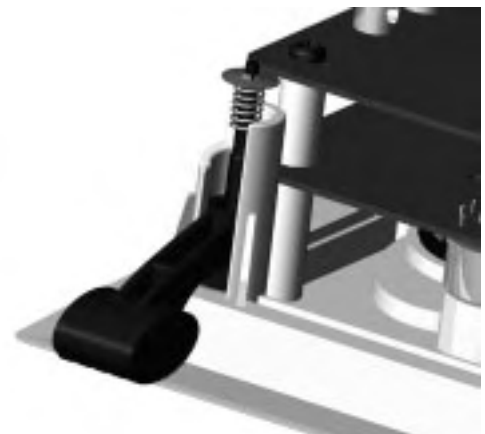

IMPORTANT

Get all the clamps in the rest position by loosening all screws before attempting to remove the speaker from the wall.

NOTE

SPEAKER LOADING VOLUME

There are two simple approaches to achieve a sealed 'enclosure' to provide the correct driver loading area behind the speaker. The chosen method will depend on whether the wall is under construction, as in a new building project, or an existing wall where access is limited.

Option 1

Stud partition walls under construction, with 102mm by 51mm (4 by 2 inch) timber at 406mm (16 inch) centres.

Insert timber framing barriers above, below, and to each side of where the speaker will be installed to create the desired loading volume. The optimum speaker loading volume for the iw4DC is 5 litres. Please refer to fig 1 below for the recommended distances between each barrier for 4" cavity depths.

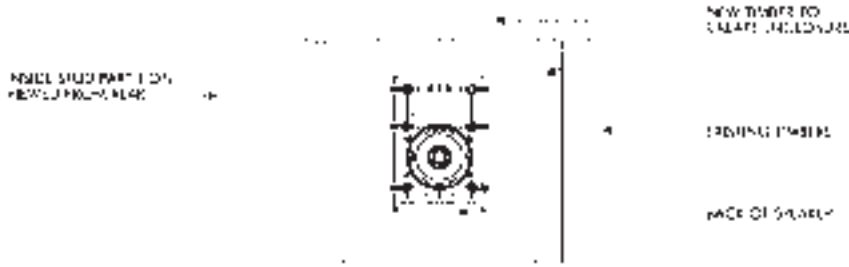

FIG 1 | HOW TO CREATE A 5 LITRE LOADING VOLUME FOR THE iw4DC

Option 2

Existing timber stud partition, or any other wall type with constructed with a 406mm (4 inch) cavity depth.

Many professional installers use a 'doughnut' of compliant material, which can be inserted as a tight fit between the two surfaces of the partition or into the wall cavity. The length of the internal surface of the strip of material determines the 'enclosure' volume. Cutting the strip to the length shown below and joining to form a ring will ensure the correct volumes. The diameter of the 'doughnut' should be 10" - this will provide a 5 litre volume (see fig 2).

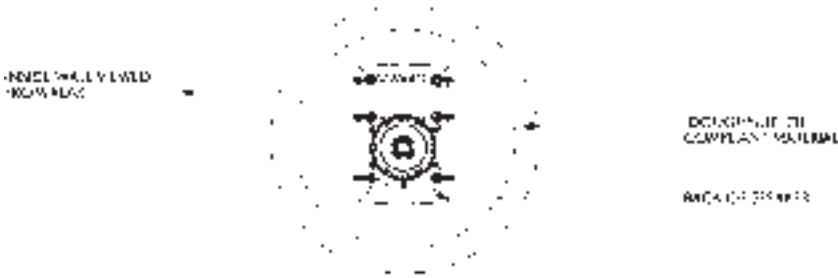

FIG 2 | STUD PARTITION OR WALL CAVITY USING COMPLIANT MATERIAL OF APPROPRIATE THICKNESS TO CREATE TIGHT SEAL



iw4 DC

TANNOY®

TECHNICAL SPECIFICATIONS

System	iw4DC	
Frequency Response (-3dB) (1)	82Hz - 50kHz	
Frequency Range (-10dB) (1)	76Hz - 54kHz	
System Sensitivity (1W @1m) (2)	88dB (1W = 2.83V for 8Ω)	
Nominal Coverage Angle	90 degrees conical	
Coverage Angle (1kHz to 6kHz)	130 degrees	
Directivity Factor (Q)	4.4 averaged 1kHz to 6kHz	
Directivity Index (DI)	5.25 averaged 1kHz to 6kHz	
Rated Maximum SPL	106dB (average) 112dB (peak)	
Power Handling (3)		
Average	60W	
Programme	120W	
Peak	240W	
Recommended Amplifier Power	120W @ 8Ω	
Nominal Impedance	8Ω	
Transformer Taps (via front rotary switch)	NA	
70V	NA	
100V	NA	
Distortion		
10% Full Power	2nd Harmonic	3rd Harmonic
250Hz	0.607%	0.553%
1kHz	1.45%	0.677%
10kHz	0.854%	0.126%
10% Full Power	2nd Harmonic	3rd Harmonic
250Hz	0.483%	0.871%
1kHz	0.436%	0.360%
10kHz	0.429%	0.055%
Crossover Point	2kHz - 2nd order LF, 2nd Order HF (with Dynamic HF protection)	
<small>Notes</small>		
<small>(1) Average over stated Bandwidth. Measured in an IEC baffle in an Anechoic Chamber</small>		
<small>(2) Unweighted Pink noise input, measured at 1m on axis*</small>		
<small>(3) Long term power handling capacity as defined in EIA - 426B test</small>		

Transducers	
Low Frequency	100mm (4.00") Mineral Loaded
High Frequency	19mm (0.75")
Physical	
Enclosure	
Baffle	Reflex loaded UL 94V-0 rated ABS
Grille	Aluminium , with weather resistant coating
Connectors	Spring Loaded. Gold Plated
Safety Agency Ratings (pending)	UL-1480, UL-2043, CE
Net Weight (ea)	2.60kg
Included Accessories	NA
Optional Accessories	NA

APPLICATIONS

Multizone Foreground Music & Paging Systems
Home Cinema
Boardrooms & Offices
Business Music Systems
Reception/ Waiting Rooms
Houses of Worship
Retail Outlets/ Shopping Malls
Lounges/ Bars

FEATURES

4" Point Source Dual Concentric Driver
High Power & High Sensitivity with extended frequency response and very low distortion
"Wide, controlled constant directivity dispersion for optimum coverage."
Does not suffer from massive loss of energy in the vertical plane at crossover caused by two way discreet designs
UV/weather resistant UL94V-0 ABS front baffle
Dynamic High Frequency Protection
Ferrofluid cooled Neodymium HF

ARCHITECTURAL SPECIFICATIONS

The in-wall system shall consist of a 100mm (4") full range, point source, constant directivity Dual Concentric_ transducer and passive frequency dividing network mounted in a vented, injection moulded, paintable front baffle in UL94V-0 ABS material. Performance of the inwall loudspeaker shall meet or exceed the following criteria: The system shall have a conical coverage pattern of 130degrees (1kHz to 6kHz). Frequency response measured on axis shall be 76 Hz -54kHz (-10dB from rated sensitivity, measured in an IEC baffle in an anechoic chamber) with no equalization. Sensitivity shall be 88dB (1W @ 1m). Long term power handling capacity as defined in EIA-426B test shall be 60W, recommended amplifier power 120W. Dynamic high frequency protection is provided for occasional overpowering. The nominal system impedance shall be 8Ω. A weather resistant perforated steel grill covers the transducer. The dimensions shall not exceed 240mm x 160mm, overall depth from the front of the baffle to the back of the driver shall not exceed 90mm. The in-wall system shall be the.....iw4 DC.

iw4DC

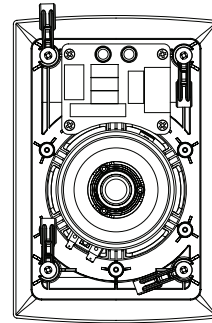
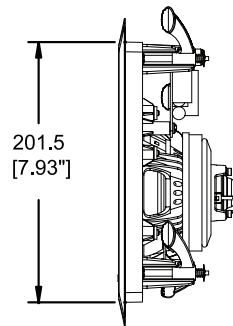
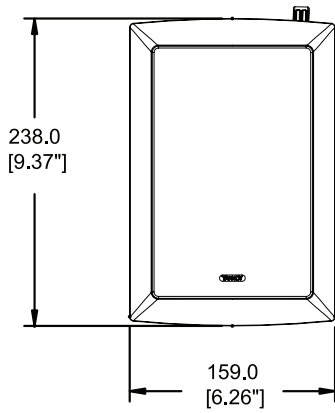
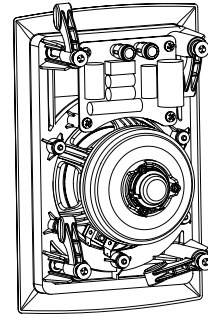
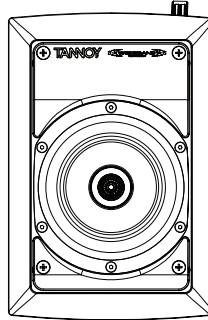
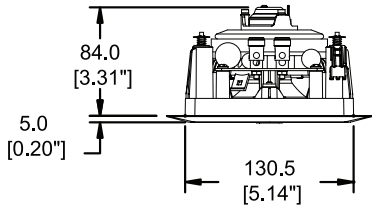

TEMPLATE HOLE CUTOUT SIZE - 206mm x 135mm

TANNOY® | IN | WALL |  DUAL™
CONCENTRIC |  WIDEBAND™
TECHNOLOGY

Tannoy Direct (UK)
TCGI (ROW sales)
TCGA (Americas sales)
Tannoy Middle East

T: 00 44 (0) 1236 420199
T: 00 45 8742 7000
T: 00 1 (519) 745 1158
T: 00 971 (04) 4401208

E: enquiries@tannoy.com
E: info@tcgroup-international.com
E: info@tcgroup-americas.com
E: enquiries@tannoy.com

tannoy.com